

Centerstand for Harley-Davidsons FL, FLH & FLT Installation Instructions Part# HD001

Note; Screamin Eagles & models with lowering kits (shorter shock absorbers) must use #HD001A

1. Remove the hourglass shaped reinforcing plate from the RIVCO centerstand assembly.
2. While lying under the right side of the motorcycle, locate the large hourglass shaped cross member. See diagram #1.
3. Clean off any dirt or gravel from the topside of the cross member. Visually inspect the cross member to see that it is not bent upwards or that the flanges are bent. See diagram #2. Some cross members & flanges may be bent from lifting or jacking the motorcycle, striking a curb, loading ramp, road debris, etc. If bent straighten it with a hammer, adjustable crescent wrench, vise grips, etc, before installing the center stand.
4. On some models there is a wire connector located on top of the cross member, next to the right frame rail. See diagram #1. If your bike has this you will need to unhook it from its tab or cut the cable tie on the cross member & push it out of the way. This will allow clearance for the centerstand hinge bracket.
5. Using a 9/16" wrench, loosen the pivot nuts on the center stand slightly. Rotate the upper hinge brackets approximately 30 degrees past parallel with the centerstand. See diagram #2. Tighten the nut enough to overcome the return spring and hold the hinge bracket in place.
6. See diagram #2. Slide the stand underneath the motorcycle with the hinge brackets going over the top of the frame cross member as far forward as it will go. Center the bolt holes left to right on the large holes in the cross member.
7. Install the reinforcing plate using the provided bolts and washers. NOTE; The plate has a slight "V" shape bend when viewed from the end. The point of the "V" should face downwards towards the ground. Before tightening check that the centerstand hinge brackets are as far forward as possible and centered between the frame rails, then tighten the bolts securely.
8. Loosen the two 9/16" pivot nuts. The stand should pivot up and down freely. If not loosen the mounting bolts and adjust the hinge brackets accordingly until the stand will move freely when the mounting bolts are tightened securely. (This binding usually happens when the cross member has been damaged or bent.)
9. Remove the 9/16" nuts completely. Remove all 4 washers on the studs. Reinstall only the washers with the smaller holes. Reinstall and tighten the pivot nuts. (The washers with the larger hole were provided to align the hinge bracket and to overcome the spring making installation easier.)
10. With the centerstand in the retracted position, notice where the stand rubber bumper contacts the oil pan. Clean this area with rubbing alcohol. Using silicone or an epoxy adhesive, glue the supplied 5/16" washer to the oil pan centered directly over the spot that the bumper contacts the oil pan. You can leave the stand in the retracted position to hold the washer in place until the glue sets.
11. Check to see that there is 1/4"-1/2" clearance between the left foot of the centerstand and the drive belt. To adjust the clearance, add or remove one or more of the 1/4" washers that are below the centerstand stops rubber bumper.

THE INSTALLATION IS NOW COMPLETE – CONGRATULATIONS!!!

USING YOUR CENTERSTAND

The centerstand is designed using the principles of leverage,
"NOT YOUR BACK" to raise the rear wheel off the ground.

1. Stand on the left side of the motorcycle with your left hand on the left handlebar and your right hand on the saddlebag guardrail. Stand the motorcycle upright to its balancing point. Put the ball of your foot squarely over the centerstand pedal.
2. As the stand touches the ground, slightly rock the motorcycle side-to-side making sure both footpads of the stand are contacting the ground.
3. Apply all of your weight to the pedal, (STAND ON IT) at the same time lifting up and pulling back on the guardrail.
4. Your bike is now "STANDING" on its own!!! Thank you for using a RIVCO product.

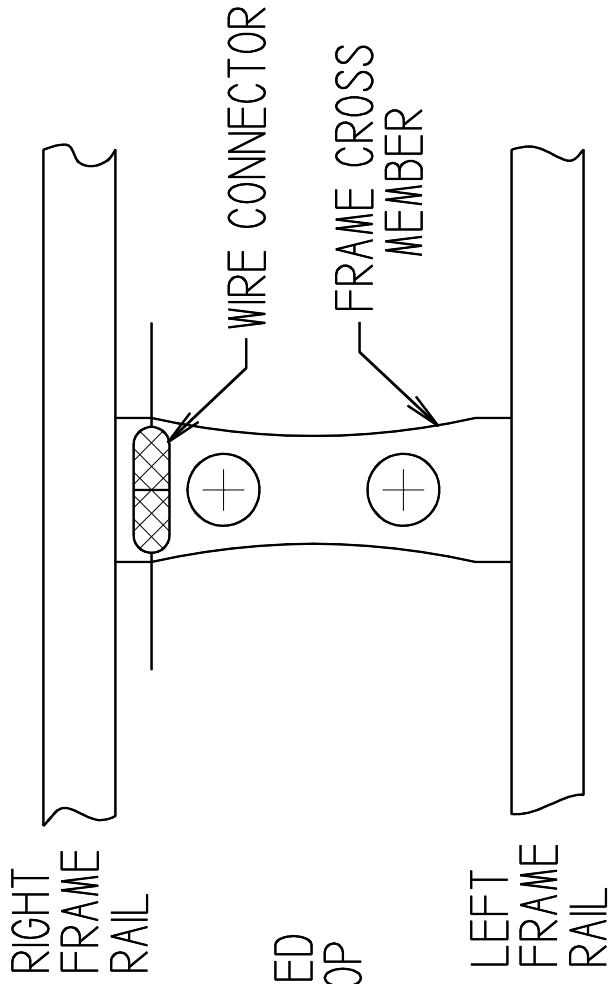

1 AS VIEWED FROM TOP

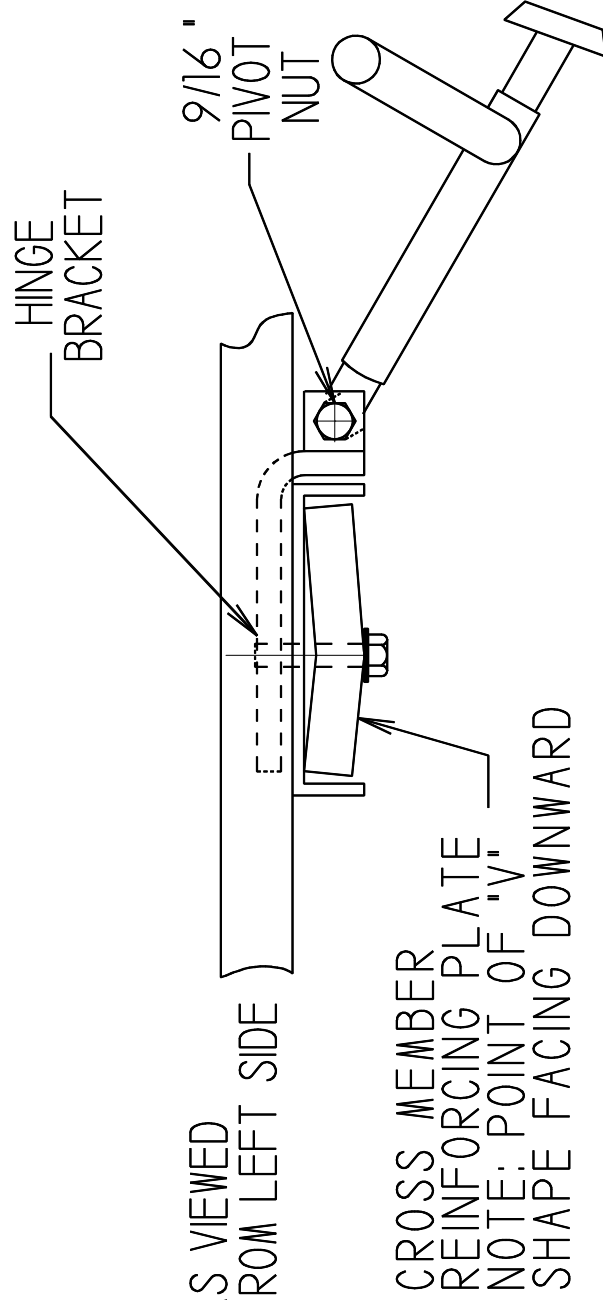

2 AS VIEWED FROM LEFT SIDE